



此图仅供参考，出货规格详见尺寸图面  
The picture is just for the reference. Please check the the actual dimensions on the drawing.

|                        |        |                       |          |                      |      |                    |       |                      |          |
|------------------------|--------|-----------------------|----------|----------------------|------|--------------------|-------|----------------------|----------|
| 最大行程<br>Maximum Stroke | 1500mm | 最高速度<br>Maximum Speed | 2000mm/s | 电机容量<br>Motor Output | 750W | 滚珠丝杆<br>Ball Screw | ø25mm | 直线滑轨<br>Linear Guide | 23X18-2支 |
|------------------------|--------|-----------------------|----------|----------------------|------|--------------------|-------|----------------------|----------|

## 型号表示方式 Ordering Method

# RTH22 - 10 - 100 - E - M75B - C 4 - 01

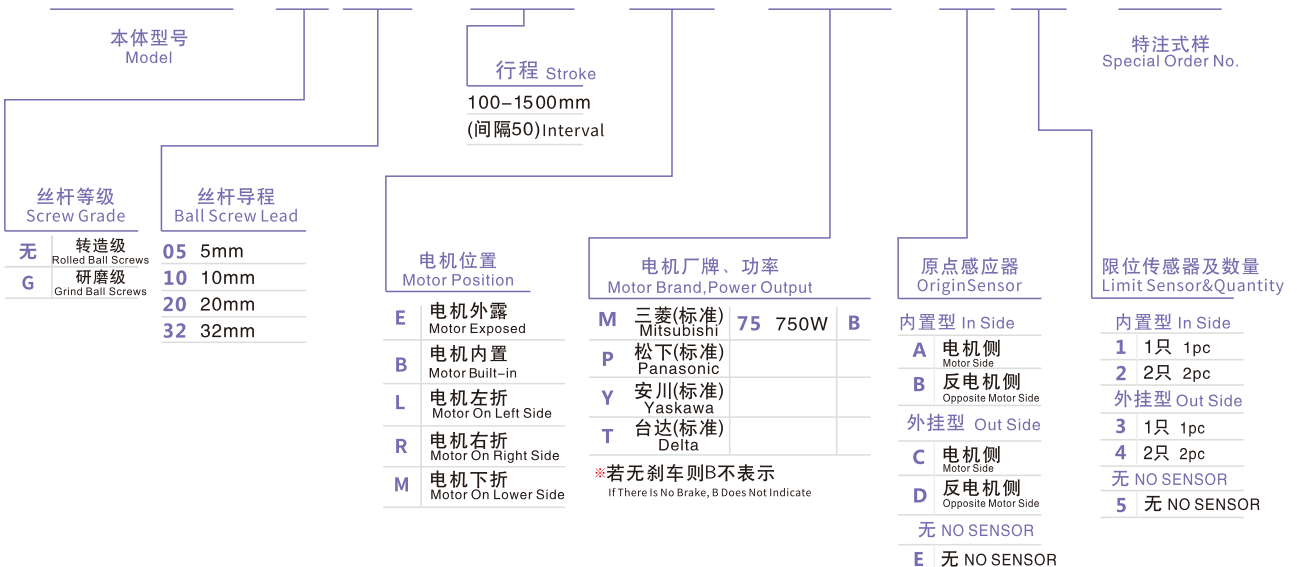

## 基本式样 Specification

|                                    |   |                           |      |              |      |    |
|------------------------------------|---|---------------------------|------|--------------|------|----|
| 性能<br>Performance                  | 位置重复精度 Repeatability (mm)               | ±0.01                     |      |              |      |    |
|                                    | 丝杆导程 Ball Screw Lead (mm)               | 5                         | 10   | 25           | 40   |    |
|                                    | 最高速度 Maximum Speed (mm/s)               | 250                       | 500  | 1250         | 2000 |    |
|                                    | 最大可搬重量<br>Maximum Payload               | 水平使用kg<br>Horizontal (kg) | 150  | 150          | 105  | 43 |
|                                    |   | 垂直使用kg<br>Vertical (kg)   | 55   | 45           | 20   | 12 |
|                                    | 定格推力 Rated Thrust (N)                   | 2563                      | 1281 | 640          | 320  |    |
| 部品<br>Parts                        | 标准行程 Stroke Pitch (mm)                  | 100~1500mm/50间隔 Interval  |      |              |      |    |
|                                    | AC伺服电机容量 AC Servo Motor Output (W)      | 750                       |      |              |      |    |
|                                    | 滚珠丝杆外径 Ball Screw $\phi$ (mm)           | C7 $\phi$ 25              |      | C7 $\phi$ 20 |      |    |
|                                    | 高刚性直线滑轨 High Rigidity Linear Guide (mm) | W23XH18                   |      |              |      |    |
|                                    | 联轴器 Coupling (mm)                       | $\phi$ 17- $\phi$ 19      |      | 12X19        |      |    |
| 原点及限位感应器*<br>Origin & Limit Sensor | 外挂<br>Outside                           | EE-SX672(NPN)             |      |              |      |    |
|                                    | 内置<br>Built-in                          | EE-SX674(NPN)             |      |              |      |    |

- \*1. 有关传感器另外的选型, 如有需求请洽询我司业务。  
 \*1. For additional selection of sensors, please contact our business if you have any requirements.  
 \*行程超过900时, 会产生丝杆偏摆, 此时请将速度调降。  
 \*When the stroke is over 900 mm, the run-out of the ballscrew will occur. We recommend to low down the working speed under this circumstances.  
 \*电机加减速设定0.2秒。  
 \*Acceleration and deceleration value is set 0.2 second.

## 容许负载悬矩表 Allowable Overhang

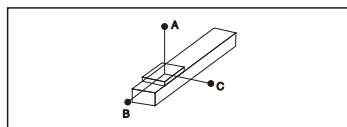

(单位: mm) (Unit: mm)

| 水平安装<br>Horizontal Installation |       |      |      |      |
|---------------------------------|-------|------|------|------|
| 导程<br>Lead                      | 重量    | A    | B    | C    |
| 导程<br>5<br>Lead                 | 100kg | 5000 | 633  | 557  |
|                                 | 125kg | 3880 | 491  | 431  |
|                                 | 150kg | 3357 | 396  | 347  |
| 导程<br>10<br>Lead                | 100kg | 3220 | 563  | 474  |
|                                 | 125kg | 3554 | 434  | 367  |
|                                 | 150kg | 2113 | 349  | 295  |
| 导程<br>25<br>Lead                | 65kg  | 1522 | 614  | 458  |
|                                 | 85kg  | 1136 | 451  | 336  |
|                                 | 105kg | 893  | 350  | 262  |
| 导程<br>40<br>Lead                | 18kg  | 2445 | 1616 | 1052 |
|                                 | 30kg  | 1436 | 938  | 613  |
|                                 | 43kg  | 978  | 630  | 412  |

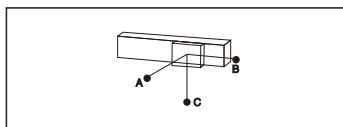

(单位: mm) (Unit: mm)

| 墙面安装<br>Wall Installation |       |      |      |      |
|---------------------------|-------|------|------|------|
| 导程<br>Lead                | 重量    | A    | B    | C    |
| 导程<br>5<br>Lead           | 110kg | 500  | 569  | 4500 |
|                           | 130kg | 412  | 469  | 3711 |
|                           | 150kg | 347  | 396  | 3357 |
| 导程<br>10<br>Lead          | 110kg | 427  | 503  | 2900 |
|                           | 130kg | 351  | 414  | 2444 |
|                           | 150kg | 295  | 349  | 2113 |
| 导程<br>25<br>Lead          | 70kg  | 420  | 564  | 1404 |
|                           | 90kg  | 315  | 420  | 1066 |
|                           | 105kg | 262  | 350  | 893  |
| 导程<br>40<br>Lead          | 15kg  | 1272 | 1955 | 2948 |
|                           | 24kg  | 778  | 1190 | 1813 |
|                           | 43kg  | 412  | 630  | 978  |

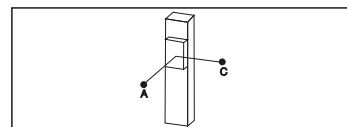

(单位: mm) (Unit: mm)

| 垂直安装<br>Vertical Installation |      |      |      |
|-------------------------------|------|------|------|
| 导程<br>Lead                    | 重量   | A    | C    |
| 导程<br>5<br>Lead               | 30kg | 2355 | 2355 |
|                               | 40kg | 1768 | 1768 |
|                               | 55kg | 1288 | 1288 |
| 导程<br>10<br>Lead              | 25kg | 2505 | 2505 |
|                               | 35kg | 1795 | 1795 |
|                               | 45kg | 1396 | 1396 |
| 导程<br>25<br>Lead              | 15kg | 2711 | 2711 |
|                               | 20kg | 2033 | 2033 |
|                               | -    | -    | -    |
| 导程<br>40<br>Lead              | 7kg  | 3511 | 3511 |
|                               | 12kg | 2055 | 2055 |
|                               | -    | -    | -    |

## 感应器接线图<原点及限位> Sensor Wiring Diagram<Origin And Limit>

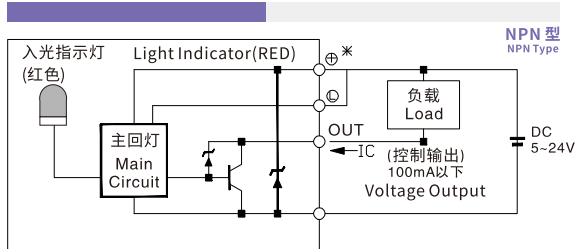

## 静态容许负载惯量 Static Allowable Load Inertia

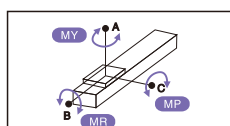

| MY        | MP        | MR        |
|-----------|-----------|-----------|
| 2052(N.m) | 2052(N.m) | 1810(N.m) |

- \*悬矩表所表示的数据, 代表重心。  
 \*The torque value in the chart indicate the center of gravity.  
 \*符合型号规范的正常使用下, 保证寿命为10000公里。  
 \*Operation life is 10,000km when the product is using under the specified conditions.  
 \*倒吊使用无法套用标准规范, 如有需求请洽询我司业务。  
 \*Data information is not for ceiling-mount inverse use. Contact us for the details if you want to apply ceiling-mount inverse usage.

### E 电机外露 Motor Exposed

(单位Unit: N.m)

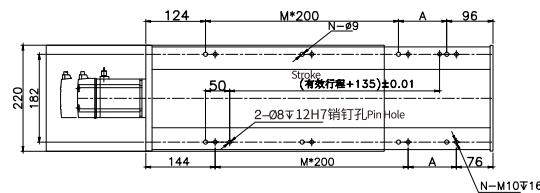
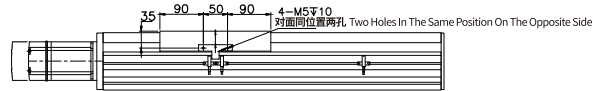
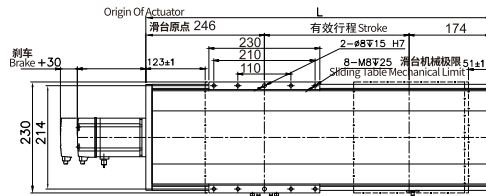
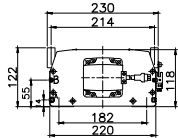
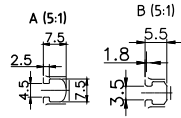

| 有效行程<br>Stroke | 100   | 150   | 200   | 250   | 300  | 350   | 400   | 450   | 500   | 550 | 600   | 650   | 700   | 750   | 800  | 850   | 900   | 950   | 1000  | 1050 | 1100  | 1150  | 1200  | 1250  | 1300 | 1350  | 1400  | 1450  | 1500  |    |
|----------------|-------|-------|-------|-------|------|-------|-------|-------|-------|-----|-------|-------|-------|-------|------|-------|-------|-------|-------|------|-------|-------|-------|-------|------|-------|-------|-------|-------|----|
| L              | 520   | 570   | 620   | 670   | 720  | 770   | 820   | 870   | 920   | 970 | 1020  | 1070  | 1120  | 1170  | 1220 | 1270  | 1320  | 1370  | 1420  | 1470 | 1520  | 1570  | 1620  | 1670  | 1720 | 1770  | 1820  | 1870  | 1920  |    |
| A              | 100   | 150   | 200   | 50    | 100  | 150   | 200   | 50    | 100   | 150 | 200   | 50    | 100   | 150   | 200  | 50    | 100   | 150   | 200   | 50   | 100   | 150   | 200   | 50    | 100  | 150   | 200   | 50    | 100   |    |
| M              | 1     | 1     | 1     | 2     | 2    | 2     | 2     | 3     | 3     | 3   | 3     | 4     | 4     | 4     | 4    | 5     | 5     | 5     | 5     | 6    | 6     | 6     | 6     | 7     | 7    | 7     | 7     | 8     | 8     |    |
| N              | 6     | 6     | 6     | 8     | 8    | 8     | 8     | 10    | 10    | 10  | 10    | 10    | 12    | 12    | 12   | 12    | 14    | 14    | 14    | 14   | 16    | 16    | 16    | 16    | 18   | 18    | 18    | 18    | 20    | 20 |
| KG             | 26.86 | 28.32 | 29.78 | 31.24 | 32.7 | 34.16 | 35.62 | 37.08 | 38.54 | 40  | 41.46 | 42.92 | 44.38 | 45.84 | 47.3 | 48.76 | 50.22 | 51.68 | 53.14 | 54.6 | 56.06 | 57.52 | 58.98 | 60.44 | 61.9 | 63.36 | 64.82 | 66.28 | 67.74 |    |

### B 电机内置 Motor Built-in

(单位Unit: N.m)

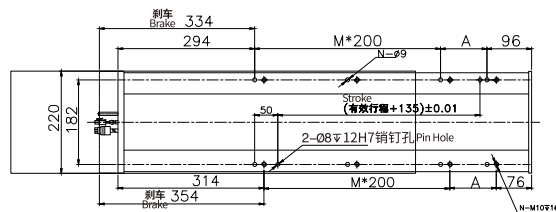
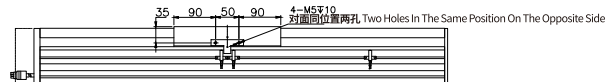
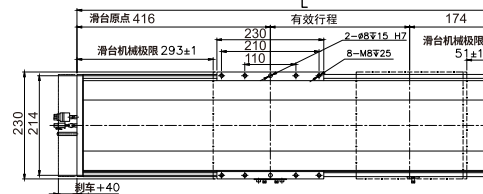
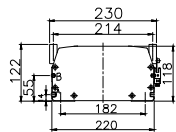
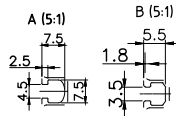

| 有效行程<br>Stroke | 100   | 150   | 200   | 250   | 300  | 350   | 400   | 450   | 500   | 550   | 600   | 650   | 700   | 750   | 800  | 850   | 900   | 950   | 1000  | 1050  | 1100  | 1150  | 1200  | 1250  | 1300 | 1350  | 1400  | 1450  | 1500  |    |
|----------------|-------|-------|-------|-------|------|-------|-------|-------|-------|-------|-------|-------|-------|-------|------|-------|-------|-------|-------|-------|-------|-------|-------|-------|------|-------|-------|-------|-------|----|
| L              | 690   | 740   | 790   | 840   | 890  | 940   | 990   | 1040  | 1090  | 1140  | 1190  | 1240  | 1290  | 1340  | 1390 | 1440  | 1490  | 1540  | 1590  | 1640  | 1690  | 1740  | 1790  | 1840  | 1890 | 1940  | 1990  | 2040  | 2090  |    |
| A              | 100   | 150   | 200   | 50    | 100  | 150   | 200   | 50    | 100   | 150   | 200   | 50    | 100   | 150   | 200  | 50    | 100   | 150   | 200   | 50    | 100   | 150   | 200   | 50    | 100  | 150   | 200   | 50    | 100   |    |
| M              | 1     | 1     | 1     | 2     | 2    | 2     | 2     | 3     | 3     | 3     | 3     | 4     | 4     | 4     | 4    | 5     | 5     | 5     | 5     | 6     | 6     | 6     | 6     | 7     | 7    | 7     | 7     | 8     | 8     |    |
| N              | 6     | 6     | 6     | 8     | 8    | 8     | 8     | 10    | 10    | 10    | 10    | 10    | 12    | 12    | 12   | 12    | 14    | 14    | 14    | 14    | 16    | 16    | 16    | 16    | 18   | 18    | 18    | 18    | 20    | 20 |
| KG             | 29.32 | 30.79 | 32.26 | 33.73 | 35.2 | 36.67 | 38.14 | 39.61 | 41.08 | 42.55 | 44.02 | 45.49 | 46.96 | 48.43 | 49.9 | 51.37 | 52.84 | 54.31 | 55.78 | 57.25 | 58.72 | 60.19 | 61.66 | 63.13 | 64.6 | 66.07 | 67.54 | 69.01 | 70.48 |    |

# 电机左折/电机右折

Motor On Left Side/Motor On Right Side

## L 电机左折 Motor On Left Side

(单位Unit: N.m)

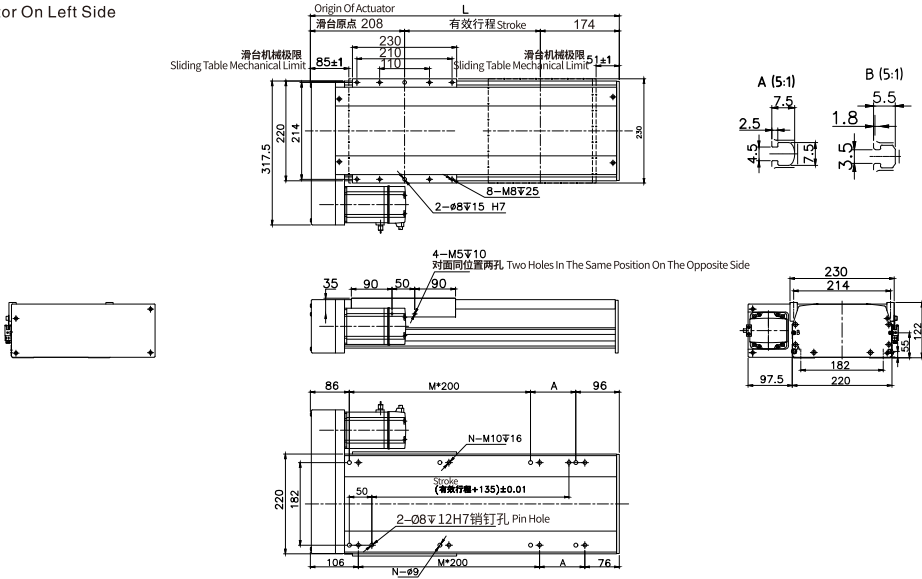

| 有效行程 Stroke | 100   | 150   | 200   | 250   | 300  | 350   | 400   | 450   | 500   | 550  | 600   | 650   | 700   | 750   | 800  | 850   | 900   | 950   | 1000  | 1050 | 1100  | 1150  | 1200  | 1250  | 1300 | 1350  | 1400  | 1450  | 1500  |    |
|-------------|-------|-------|-------|-------|------|-------|-------|-------|-------|------|-------|-------|-------|-------|------|-------|-------|-------|-------|------|-------|-------|-------|-------|------|-------|-------|-------|-------|----|
| L           | 482   | 532   | 582   | 632   | 682  | 732   | 782   | 832   | 882   | 932  | 982   | 1032  | 1082  | 1132  | 1182 | 1232  | 1282  | 1332  | 1382  | 1432 | 1482  | 1532  | 1582  | 1632  | 1682 | 1732  | 1782  | 1832  | 1882  |    |
| A           | 100   | 150   | 200   | 50    | 100  | 150   | 200   | 50    | 100   | 150  | 200   | 50    | 100   | 150   | 200  | 50    | 100   | 150   | 200   | 50   | 100   | 150   | 200   | 50    | 100  | 150   | 200   | 50    | 100   |    |
| M           | 1     | 1     | 1     | 2     | 2    | 2     | 2     | 3     | 3     | 3    | 3     | 4     | 4     | 4     | 4    | 5     | 5     | 5     | 5     | 5    | 6     | 6     | 6     | 6     | 7    | 7     | 7     | 8     | 8     |    |
| N           | 6     | 6     | 6     | 8     | 8    | 8     | 8     | 10    | 10    | 10   | 10    | 12    | 12    | 12    | 12   | 14    | 14    | 14    | 14    | 14   | 16    | 16    | 16    | 16    | 18   | 18    | 18    | 18    | 20    | 20 |
| KG          | 25.66 | 27.12 | 28.58 | 30.04 | 31.5 | 32.96 | 34.42 | 35.88 | 37.34 | 38.8 | 40.26 | 41.72 | 43.18 | 44.64 | 46.1 | 47.56 | 49.02 | 50.48 | 51.94 | 53.4 | 54.86 | 56.32 | 57.78 | 59.24 | 60.7 | 62.16 | 63.62 | 65.08 | 66.54 |    |

## R 电机右折 Motor On Right Side

(单位Unit: N.m)

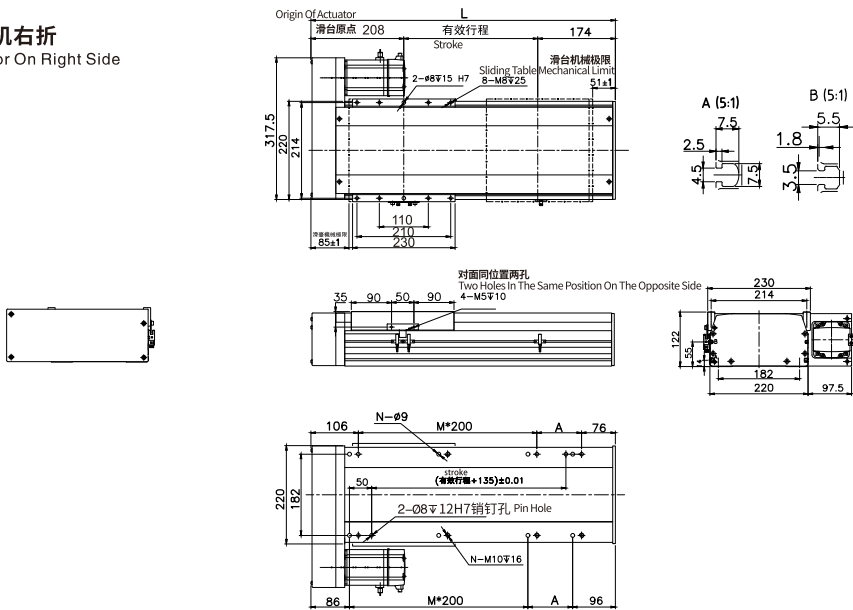

| 有效行程 Stroke | 100   | 150   | 200   | 250   | 300  | 350   | 400   | 450   | 500   | 550  | 600   | 650   | 700   | 750   | 800  | 850   | 900   | 950   | 1000  | 1050 | 1100  | 1150  | 1200  | 1250  | 1300 | 1350  | 1400  | 1450  | 1500  |    |
|-------------|-------|-------|-------|-------|------|-------|-------|-------|-------|------|-------|-------|-------|-------|------|-------|-------|-------|-------|------|-------|-------|-------|-------|------|-------|-------|-------|-------|----|
| L           | 482   | 532   | 582   | 632   | 682  | 732   | 782   | 832   | 882   | 932  | 982   | 1032  | 1082  | 1132  | 1182 | 1232  | 1282  | 1332  | 1382  | 1432 | 1482  | 1532  | 1582  | 1632  | 1682 | 1732  | 1782  | 1832  | 1882  |    |
| A           | 100   | 150   | 200   | 50    | 100  | 150   | 200   | 50    | 100   | 150  | 200   | 50    | 100   | 150   | 200  | 50    | 100   | 150   | 200   | 50   | 100   | 150   | 200   | 50    | 100  | 150   | 200   | 50    | 100   |    |
| M           | 1     | 1     | 1     | 2     | 2    | 2     | 2     | 3     | 3     | 3    | 3     | 4     | 4     | 4     | 4    | 5     | 5     | 5     | 5     | 5    | 6     | 6     | 6     | 6     | 7    | 7     | 7     | 8     | 8     |    |
| N           | 6     | 6     | 6     | 8     | 8    | 8     | 8     | 10    | 10    | 10   | 10    | 12    | 12    | 12    | 12   | 14    | 14    | 14    | 14    | 14   | 16    | 16    | 16    | 16    | 18   | 18    | 18    | 18    | 20    | 20 |
| KG          | 25.66 | 27.12 | 28.58 | 30.04 | 31.5 | 32.96 | 34.42 | 35.88 | 37.34 | 38.8 | 40.26 | 41.72 | 43.18 | 44.64 | 46.1 | 47.56 | 49.02 | 50.48 | 51.94 | 53.4 | 54.86 | 56.32 | 57.78 | 59.24 | 60.7 | 62.16 | 63.62 | 65.08 | 66.54 |    |

M

#### 电机下折

Motor On Lower Side

(单位Unit: N.m)

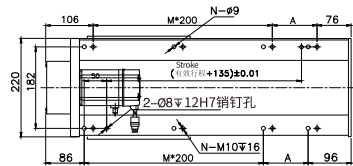
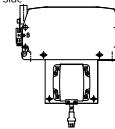
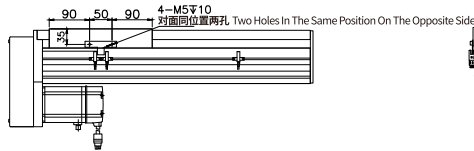
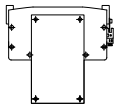
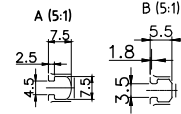
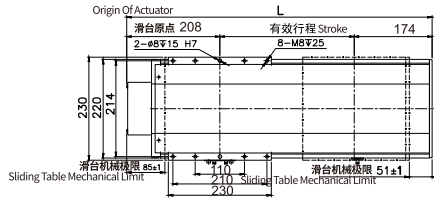

| 有效行程<br>Stroke | 100   | 150   | 200   | 250   | 300  | 350   | 400   | 450   | 500   | 550  | 600   | 650   | 700   | 750   | 800  | 850   | 900   | 950   | 1000  | 1050 | 1100  | 1150  | 1200  | 1250  | 1300 | 1350  | 1400  | 1450  | 1500  |
|----------------|-------|-------|-------|-------|------|-------|-------|-------|-------|------|-------|-------|-------|-------|------|-------|-------|-------|-------|------|-------|-------|-------|-------|------|-------|-------|-------|-------|
| L              | 482   | 532   | 582   | 632   | 682  | 732   | 782   | 832   | 882   | 932  | 982   | 1032  | 1082  | 1132  | 1182 | 1232  | 1282  | 1332  | 1382  | 1432 | 1482  | 1532  | 1582  | 1632  | 1682 | 1732  | 1782  | 1832  | 1882  |
| A              | 100   | 150   | 200   | 50    | 100  | 150   | 200   | 50    | 100   | 150  | 200   | 50    | 100   | 150   | 200  | 50    | 100   | 150   | 200   | 50   | 100   | 150   | 200   | 50    | 100  | 150   | 200   | 50    | 100   |
| M              | 1     | 1     | 1     | 2     | 2    | 2     | 2     | 3     | 3     | 3    | 3     | 4     | 4     | 4     | 4    | 5     | 5     | 5     | 5     | 6    | 6     | 6     | 6     | 7     | 7    | 7     | 7     | 8     | 8     |
| N              | 6     | 6     | 6     | 8     | 8    | 8     | 8     | 10    | 10    | 10   | 10    | 12    | 12    | 12    | 12   | 14    | 14    | 14    | 14    | 16   | 16    | 16    | 16    | 18    | 18   | 18    | 18    | 20    | 20    |
| KG             | 25.66 | 27.12 | 28.58 | 30.04 | 31.5 | 32.96 | 34.42 | 35.88 | 37.34 | 38.8 | 40.26 | 41.72 | 43.18 | 44.64 | 46.1 | 47.56 | 49.02 | 50.48 | 51.94 | 53.4 | 54.86 | 56.32 | 57.78 | 59.24 | 60.7 | 62.16 | 63.62 | 65.08 | 66.54 |