



此图仅供参考，出货规格详见尺寸图画
The picture is just for the reference. Please check the actual dimensions on the drawing.

最大行程 4050mm
Maximum Stroke

最高速度 2000mm/s
Maximum Speed

电机容量 400W
Motor Output

皮带宽度 30mm
Belt Width

直线滑轨 20X15-2支
Linear Guide

型号表示方式

Ordering Method

RTB17 - 40 - 100 - L - M40 - C 4 - 01

本体型号
Model

导程
Lead

行程 Stroke

100-4050mm
(间隔50 mm Interval)

特注式样
Special Order No.

皮带型式
Belt Type

- 无尘皮带
Rubber Belt
- 橡胶皮带
Clean Belt

电机位置
Motor Position

- L** L电机左折
L Motor On Left Side
- LW** LW电机左上折
LW Motor On Upper Left Side
- LM** LM电机左下折
LM Motor On Lower Left Side
- R** R电机右折
R Motor On Right Side
- RW** RW电机右上折
RW Motor On Upper Right Side
- RM** RM电机右下折
RM Motor On Lower Right Side

电机厂牌、功率
Motor Brand, Power Output

- | | |
|-------------------------------|----------------|
| P 松下(标准)
Panasonic | 40 400W |
| M 三菱(标准)
Mitsubishi | |
| Y 安川(标准)
Yaskawa | |
| T 台达(标准)
Delta | |

原点感应器
Origin Sensor

- C** 外挂型 Out Side
电机侧 Motor Side
- D** 反电机侧
Opposite Motor Side
- 无** NO SENSOR
- E** 无 NO SENSOR

限位传感器及数量
Limit Sensor & Quantity

- | 外挂型 Out Side | 数量 |
|----------------------|----|
| 3 1只 1pc | |
| 4 2只 2pc | |
| 无 NO SENSOR | |
| 5 无 NO SENSOR | |

基本式样 Specification

性能 Performance	位置重复精度 Repeatability(mm)		+0.04
	导程 Lead(mm)		40
	最高速度 Maximum Speed(mm/s)		2000
	最大可搬重量 Maximum Payload	水平使用 kg Horizontal(kg)	45
	定格推力 Rated Thrust(N)		204
	标准行程 Stroke Pitch(mm)		100~4050mm/50间隔Interval
部品 Parts	AC伺服马达容量 AC Servo Motor Output (w)		400
	皮带宽度 Belt Width(mm)		30
	高刚性直线滑轨 High Rigidity Linear Guide (mm)		W20XH15
	原点及限位感应器* Origin & Limit Sensor	外挂Outside	EE-SX672(NPN)

- *1. 有关传感器另外的选型，如有需求请洽询我司业务。
 *1. For additional selection of sensors, please contact our business if you have any requirements.
- *2. 电机加减速设定0.4秒。
 *2. *Acceleration and deceleration value is set 0.4 second3

容许负载悬矩表 Allowable Overhang

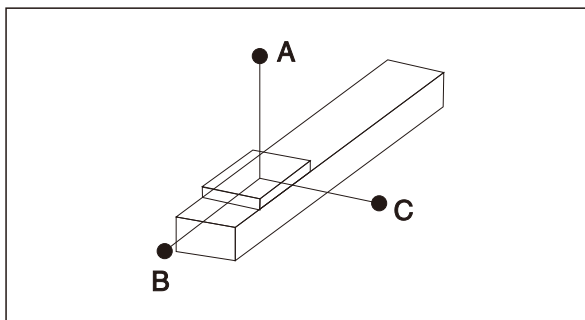

(单位: mm) (Unit: mm)

水平安装 Horizontal Installation	A	B	C
10kg	2942	1133	1033
20kg	1430	547	498
30kg	926	350	320
45kg	588	219	201

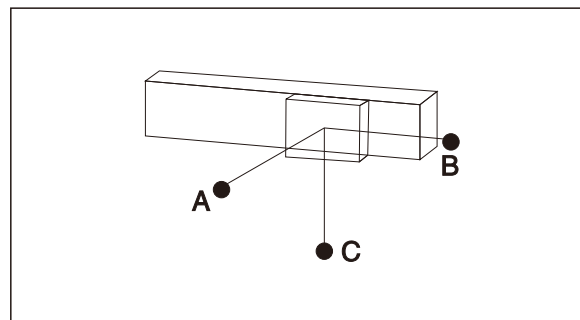

(单位: mm) (Unit: mm)

墙面安装 Wall Installation	A	B	C
15kg	676	742	1933
25kg	390	428	1127
35kg	269	294	781
45kg	201	219	588

感应器接线图<原点及限位> Sensor Wiring Diagram<Origin And Limit>

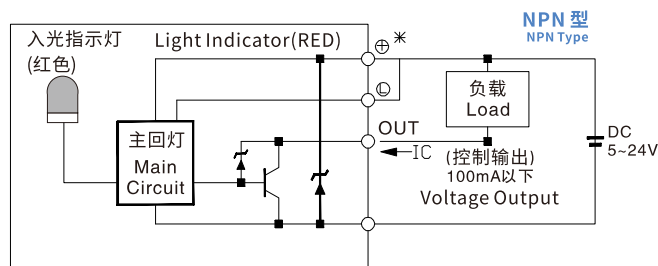

静态容许负载惯量 Static Allowable Load Inertia

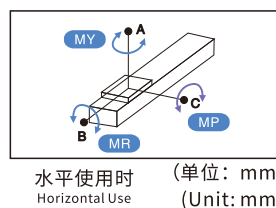

水平使用时 Horizontal Use	(单位: mm) (Unit: mm)
MY	1032
MP	1034
MR	908

- *悬矩表所表示的数据，代表重心。
 *The torque value in the chart indicate the center of gravity.
- *符合型号规范的正常使用时，
 保证寿命为10000公里。
 *Operation life is 10,000km when the product is using under the specified conditions.
- *倒吊使用无法套用标准规范，
 如有需求请洽询我司业务。
 *Data information is not for ceiling-mount inverse use.
 Contact us for the details if you want to apply ceiling-mount inverse usage.

L 电机左折 Motor On Left Side

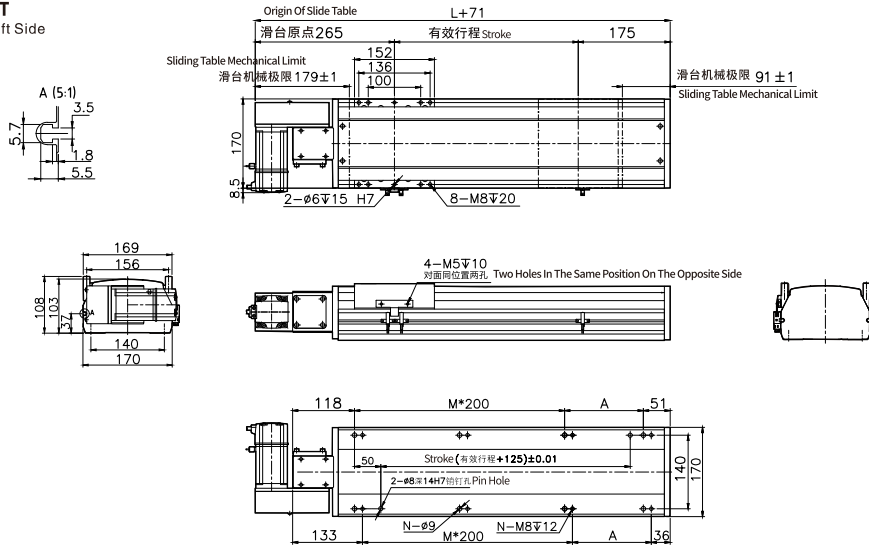

有效行程 Stroke	100	150	200	250	300	350	400	450	500	550	600	650	700	750	800	850	900	950	1000	1050	1100	1150	1200	1250	1300	1350	1400	1450	1500	1550
L	469	519	569	619	669	719	769	819	869	919	969	1019	1069	1119	1169	1219	1269	1319	1369	1419	1469	1519	1569	1619	1669	1719	1769	1819	1869	1919
A	100	150	200	50	100	150	200	50	100	150	200	50	100	150	200	50	100	150	200	50	100	150	200	50	100	150	200	50	100	150
M	1	1	1	2	2	2	2	3	3	3	3	4	4	5	4	5	5	5	6	6	6	7	7	7	7	7	8	8	8	
N	6	6	6	8	8	8	8	10	10	10	10	12	12	12	12	14	14	14	16	16	16	18	18	18	18	18	20	20	20	
KG	12	13.8	14.6	15.4	16.1	16.9	17.7	18.5	19.2	20	20.8	21.6	22.3	23.1	23.9	24.7	25.4	26.2	27	27.8	28.6	29.4	30.7	31	31.8	32.6	33.4	34.2	35	35.3

有效行程 Stroke	1600	1650	1700	1750	1800	1850	1900	1950	2000	2050	2100	2150	2200	2250	2300	2350	2400	2450	2500	2550	2600	2650	2700	2750	2800	2850	2900	2950	3000	3050
L	1969	2019	2069	2119	2169	2219	2269	2319	2369	2419	2469	2519	2569	2619	2669	2719	2769	2819	2869	2919	2969	3019	3069	3119	3169	3219	3269	3319	3369	3419
A	200	50	100	150	200	50	100	150	200	50	100	150	200	50	100	150	200	50	100	150	200	50	100	150	200	50	100	150	200	50
M	8	9	9	9	9	10	10	10	10	10	11	11	11	11	12	12	12	13	13	13	13	14	14	14	14	15	15	15	16	
N	20	22	22	22	22	24	24	24	24	24	26	26	26	26	28	28	28	28	30	30	30	30	32	32	32	32	34	34	34	36
KG	36.6	37.4	38.2	39	39.8	40.6	41.4	42.2	43	43.8	44.6	45.4	46.2	47	47.8	48.6	49.4	50.2	51	51.8	52.6	53.4	54.2	55	55.8	56.6	57.4	58.2	59	59.8

R 电机右折 Motor On Right Side

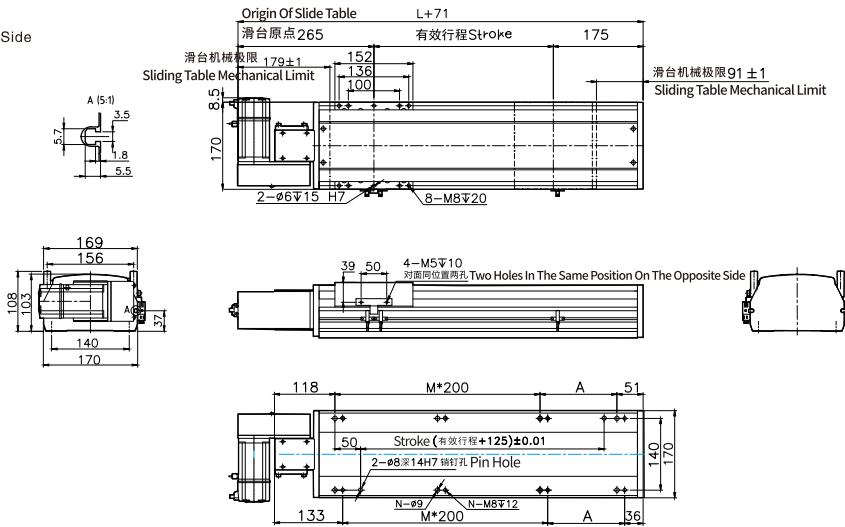

有效行程 Stroke	100	150	200	250	300	350	400	450	500	550	600	650	700	750	800	850	900	950	1000	1050	1100	1150	1200	1250	1300	1350	1400	1450	1500	1550
L	469	519	569	619	669	719	769	819	869	919	969	1019	1069	1119	1169	1219	1269	1319	1369	1419	1469	1519	1569	1619	1669	1719	1769	1819	1869	1919
A	100	150	200	50	100	150	200	50	100	150	200	50	100	150	200	50	100	150	200	50	100	150	200	50	100	150	200	50	100	150
M	1	1	1	2	2	2	2	3	3	3	3	4	4	5	4	5	5	5	6	6	6	7	7	7	7	7	8	8	8	
N	6	6	6	8	8	8	8	10	10	10	10	12	12	12	12	14	14	14	16	16	16	18	18	18	18	18	20	20	20	
KG	12	13.8	14.6	15.4	16.1	16.9	17.7	18.5	19.2	20	20.8	21.6	22.3	23.1	23.9	24.7	25.4	26.2	27	27.8	28.6	29.4	30.7	31	31.8	32.6	33.4	34.2	35	35.3

有效行程 Stroke	1600	1650	1700	1750	1800	1850	1900	1950	2000	2050	2100	2150	2200	2250	2300	2350	2400	2450	2500	2550	2600	2650	2700	2750	2800	2850	2900	2950	3000	3050
L	1969	2019	2069	2119	2169	2219	2269	2319	2369	2419	2469	2519	2569	2619	2669	2719	2769	2819	2869	2919	2969	3019	3069	3119	3169	3219	3269	3319	3369	3419
A	200	50	100	150	200	50	100	150	200	50	100	150	200	50	100	150	200	50	100	150	200	50	100	150	200	50	100	150	200	50
M	8	9	9	9	9	10	10	10	10	10	11	11	11	11	12	12	12	13	13	13	13	14	14	14	14	15	15	15	16	
N	20	22	22	22	22	24	24	24	24	24	26	26	26	26	28	28	28	28	30	30	30	30	32	32	32	32	34	34	34	36
KG	36.6	37.4	38.2	39	39.8	40.6	41.4	42.2	43	43.8	44.6	45.4	46.2	47	47.8	48.6	49.4	50.2	51	51.8	52.6	53.4	54.2	55	55.8	56.6	57.4	58.2	59	59.8

电机左下折/电机右下折

LM Motor On Lower Left Side/RM Motor On Lower Right Side

LM 电机左下折 LM Motor On Lower Left Side

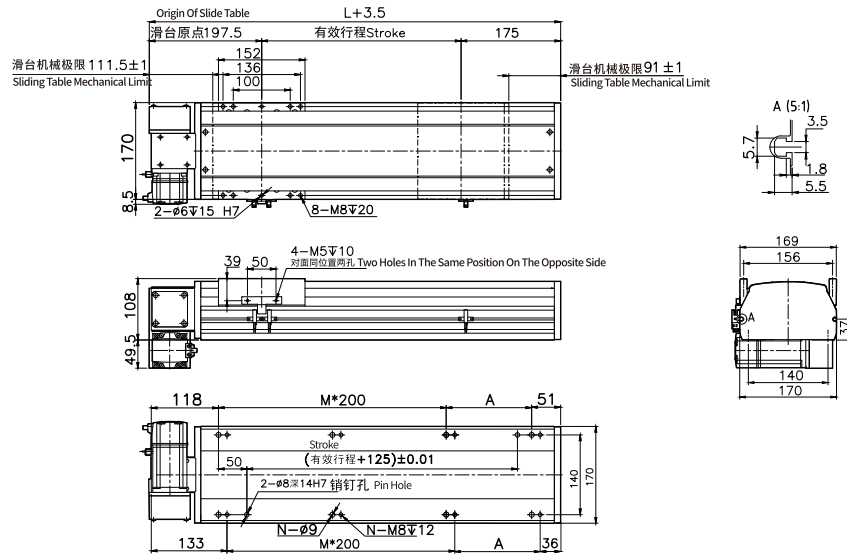

有效行程 Stroke	100	150	200	250	300	350	400	450	500	550	600	650	700	750	800	850	900	950	1000	1050	1100	1150	1200	1250	1300	1350	1400	1450	1500	1550
L	469	519	569	619	669	719	769	819	869	919	969	1019	1069	1119	1169	1219	1269	1319	1369	1419	1469	1519	1569	1619	1669	1719	1769	1819	1869	1919
A	100	150	200	50	100	150	200	50	100	150	200	50	100	150	200	50	100	150	200	50	100	150	200	50	100	150	200	50	100	150
M	1	1	1	2	2	2	2	3	3	3	3	3	4	4	5	4	5	5	5	6	6	6	6	7	7	7	7	8	8	8
N	6	6	6	8	8	8	8	10	10	10	10	12	12	12	12	14	14	14	14	16	16	16	16	18	18	18	18	20	20	20
KG	12	13.8	14.6	15.4	16.1	16.9	17.7	18.5	19.2	20	20.8	21.6	22.3	23.1	23.9	24.7	25.4	26.2	27	27.8	28.6	29.4	30.7	31	31.8	32.6	33.4	34.2	35	35.3

有效行程 Stroke	1600	1650	1700	1750	1800	1850	1900	1950	2000	2050	2100	2150	2200	2250	2300	2350	2400	2450	2500	2550	2600	2650	2700	2750	2800	2850	2900	2950	3000	3050
L	1969	2019	2069	2119	2169	2219	2269	2319	2369	2419	2469	2519	2569	2619	2669	2719	2769	2819	2869	2919	2969	3019	3069	3119	3169	3219	3269	3319	3369	3419
A	200	50	100	150	200	50	100	150	200	50	100	150	200	50	100	150	200	50	100	150	200	50	100	150	200	50	100	150	200	50
M	8	9	9	9	9	10	10	10	10	11	11	11	11	12	12	12	12	13	13	13	13	14	14	14	14	15	15	15	15	16
N	20	22	22	22	22	24	24	24	24	26	26	26	26	28	28	28	28	30	30	30	30	32	32	32	32	34	34	34	34	36
KG	36.6	37.4	38.2	39	39.8	40.6	41.4	42.2	43	43.8	44.6	45.4	46.2	47	47.8	48.6	49.4	50.2	51	51.8	52.6	53.4	54.2	55	55.8	56.6	57.4	58.2	59	59.8

RM 电机右下折 RM Motor On Lower Right Side

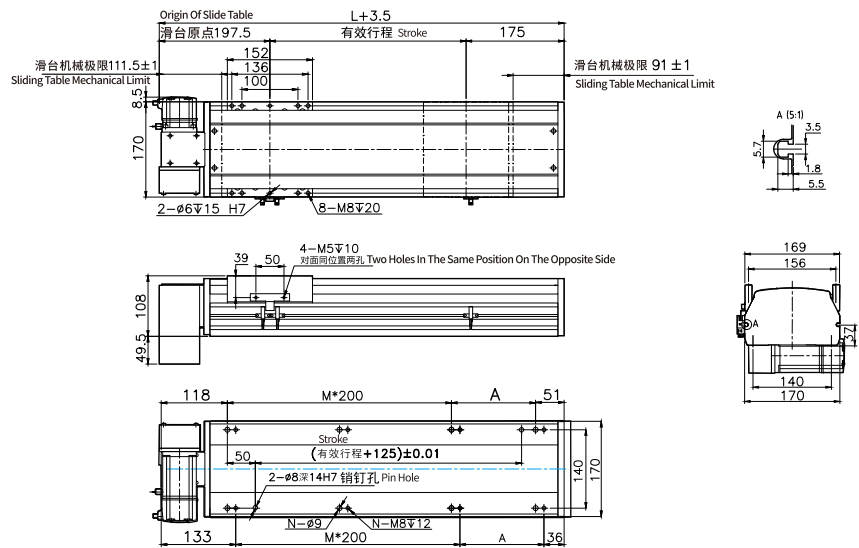

有效行程 Stroke	100	150	200	250	300	350	400	450	500	550	600	650	700	750	800	850	900	950	1000	1050	1100	1150	1200	1250	1300	1350	1400	1450	1500	1550
L	469	519	569	619	669	719	769	819	869	919	969	1019	1069	1119	1169	1219	1269	1319	1369	1419	1469	1519	1569	1619	1669	1719	1769	1819	1869	1919
A	100	150	200	50	100	150	200	50	100	150	200	50	100	150	200	50	100	150	200	50	100	150	200	50	100	150	200	50	100	150
M	1	1	1	2	2	2	2	3	3	3	3	3	4	4	5	4	5	5	5	6	6	6	6	7	7	7	7	8	8	8
N	6	6	6	8	8	8	8	10	10	10	10	12	12	12	12	14	14	14	14	16	16	16	16	18	18	18	18	20	20	20
KG	12	13.8	14.6	15.4	16.1	16.9	17.7	18.5	19.2	20	20.8	21.6	22.3	23.1	23.9	24.7	25.4	26.2	27	27.8	28.6	29.4	30.7	31	31.8	32.6	33.4	34.2	35	35.3

有效行程 Stroke	1600	1650	1700	1750	1800	1850	1900	1950	2000	2050	2100	2150	2200	2250	2300	2350	2400	2450	2500	2550	2600	2650	2700	2750	2800	2850	2900	2950	3000	3050
L	1969	2019	2069	2119	2169	2219	2269	2319	2369	2419	2469	2519	2569	2619	2669	2719	2769	2819	2869	2919	2969	3019	3069	3119	3169	3219	3269	3319	3369	3419
A	200	50	100	150	200	50	100	150	200	50	100	150	200	50	100	150	200	50	100	150	200	50	100	150	200	50	100	150	200	50
M	8	9	9	9	9	10	10	10	10	11	11	11	11	12	12	12	12	13	13	13	13	14	14	14	14	15	15	15	15	16
N	20	22	22	22	22	24	24	24	24	26	26	26	26	28	28	28	28	30	30	30	30	32	32	32	32	34	34	34	34	36
KG	36.6	37.4	38.2	39	39.8	40.6	41.4	42.2	43	43.8	44.6	45.4	46.2	47	47.8	48.6	49.4	50.2	51	51.8	52.6	53.4	54.2	55	55.8	56.6	57.4	58.2	59	59.8



电机左上折

LW Motor On Upper Left Side

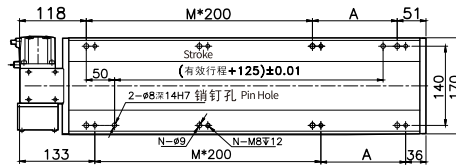
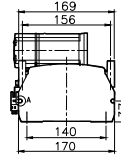
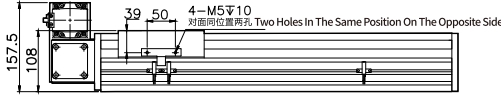
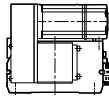
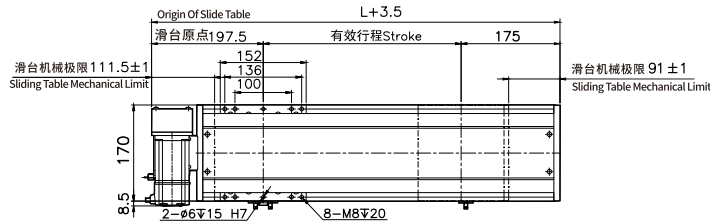

有效行程 Stroke	100	150	200	250	300	350	400	450	500	550	600	650	700	750	800	850	900	950	1000	1050	1100	1150	1200	1250	1300	1350	1400	1450	1500	1550
L	469	519	569	619	669	719	769	819	869	919	969	1019	1069	1119	1169	1219	1269	1319	1369	1419	1469	1519	1569	1619	1669	1719	1769	1819	1869	1919
A	100	150	200	50	100	150	200	50	100	150	200	50	100	150	200	50	100	150	200	50	100	150	200	50	100	150	200	50	100	150
M	1	1	1	2	2	2	2	3	3	3	3	4	4	5	4	5	5	5	5	6	6	6	6	7	7	7	7	8	8	8
N	6	6	6	8	8	8	8	8	10	10	10	10	12	12	12	12	14	14	14	14	16	16	16	16	18	18	18	20	20	20
KG	12	13.8	14.6	15.4	16.1	16.9	17.7	18.5	19.2	20	20.8	21.6	22.3	23.1	23.9	24.7	25.4	26.2	27	27.8	28.6	29.4	30.7	31	31.8	32.6	33.4	34.2	35	35.3

有效行程 Stroke	1600	1650	1700	1750	1800	1850	1900	1950	2000	2050	2100	2150	2200	2250	2300	2350	2400	2450	2500	2550	2600	2650	2700	2750	2800	2850	2900	2950	3000	3050
L	1969	2019	2069	2119	2169	2219	2269	2319	2369	2419	2469	2519	2569	2619	2669	2719	2769	2819	2869	2919	2969	3019	3069	3119	3169	3219	3269	3319	3369	3419
A	200	50	100	150	200	50	100	150	200	50	100	150	200	50	100	150	200	50	100	150	200	50	100	150	200	50	100	150	200	50
M	8	9	9	9	9	10	10	10	10	10	11	11	11	11	12	12	12	12	13	13	13	13	14	14	14	15	15	15	15	16
N	20	22	22	22	22	24	24	24	24	24	26	26	26	26	28	28	28	28	30	30	30	30	32	32	32	32	34	34	34	36
KG	36.6	37.4	38.2	39	39.8	40.6	41.4	42.2	43	43.8	44.6	45.4	46.2	47	47.8	48.6	49.4	50.2	51	51.8	52.6	53.4	54.2	55	55.8	56.6	57.4	58.2	59	59.8



电机右上折

RW Motor On Upper Right Side

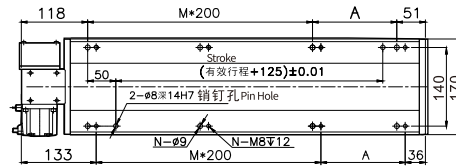
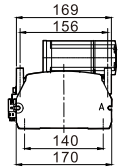
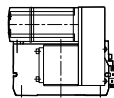
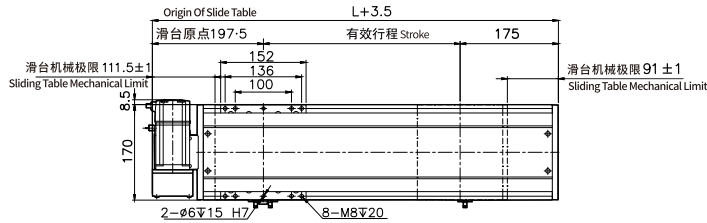

有效行程 Stroke	100	150	200	250	300	350	400	450	500	550	600	650	700	750	800	850	900	950	1000	1050	1100	1150	1200	1250	1300	1350	1400	1450	1500	1550
L	469	519	569	619	669	719	769	819	869	919	969	1019	1069	1119	1169	1219	1269	1319	1369	1419	1469	1519	1569	1619	1669	1719	1769	1819	1869	1919
A	100	150	200	50	100	150	200	50	100	150	200	50	100	150	200	50	100	150	200	50	100	150	200	50	100	150	200	50	100	150
M	1	1	1	2	2	2	2	3	3	3	3	4	4	5	4	5	5	5	5	6	6	6	6	7	7	7	7	8	8	8
N	6	6	6	8	8	8	8	10	10	10	10	12	12	12	12	14	14	14	14	16	16	16	16	18	18	18	20	20	20	20
KG	12	13.8	14.6	15.4	16.1	16.9	17.7	18.5	19.2	20	20.8	21.6	22.3	23.1	23.9	24.7	25.4	26.2	27	27.8	28.6	29.4	30.7	31	31.8	32.6	33.4	34.2	35	35.3

有效行程 Stroke	1600	1650	1700	1750	1800	1850	1900	1950	2000	2050	2100	2150	2200	2250	2300	2350	2400	2450	2500	2550	2600	2650	2700	2750	2800	2850	2900	2950	3000	3050
L	1969	2019	2069	2119	2169	2219	2269	2319	2369	2419	2469	2519	2569	2619	2669	2719	2769	2819	2869	2919	2969	3019	3069	3119	3169	3219	3269	3319	3369	3419
A	200	50	100	150	200	50	100	150	200	50	100	150	200	50	100	150	200	50	100	150	200	50	100	150	200	50	100	150	200	50
M	8	9	9	9	9	10	10	10	10	10	11	11	11	11	12	12	12	12	13	13	13	13	14	14	14	15	15	15	15	16
N	20	22	22	22	22	24	24	24	24	24	26	26	26	26	28	28	28	28	30	30	30	30	32	32	32	32	34	34	34	36
KG	36.6	37.4	38.2	39	39.8	40.6	41.4	42.2	43	43.8	44.6	45.4	46.2	47	47.8	48.6	49.4	50.2	51	51.8	52.6	53.4	54.2	55	55.8	56.6	57.4	58.2	59	59.8